

21 CIRCUIT WIRING HARNESS

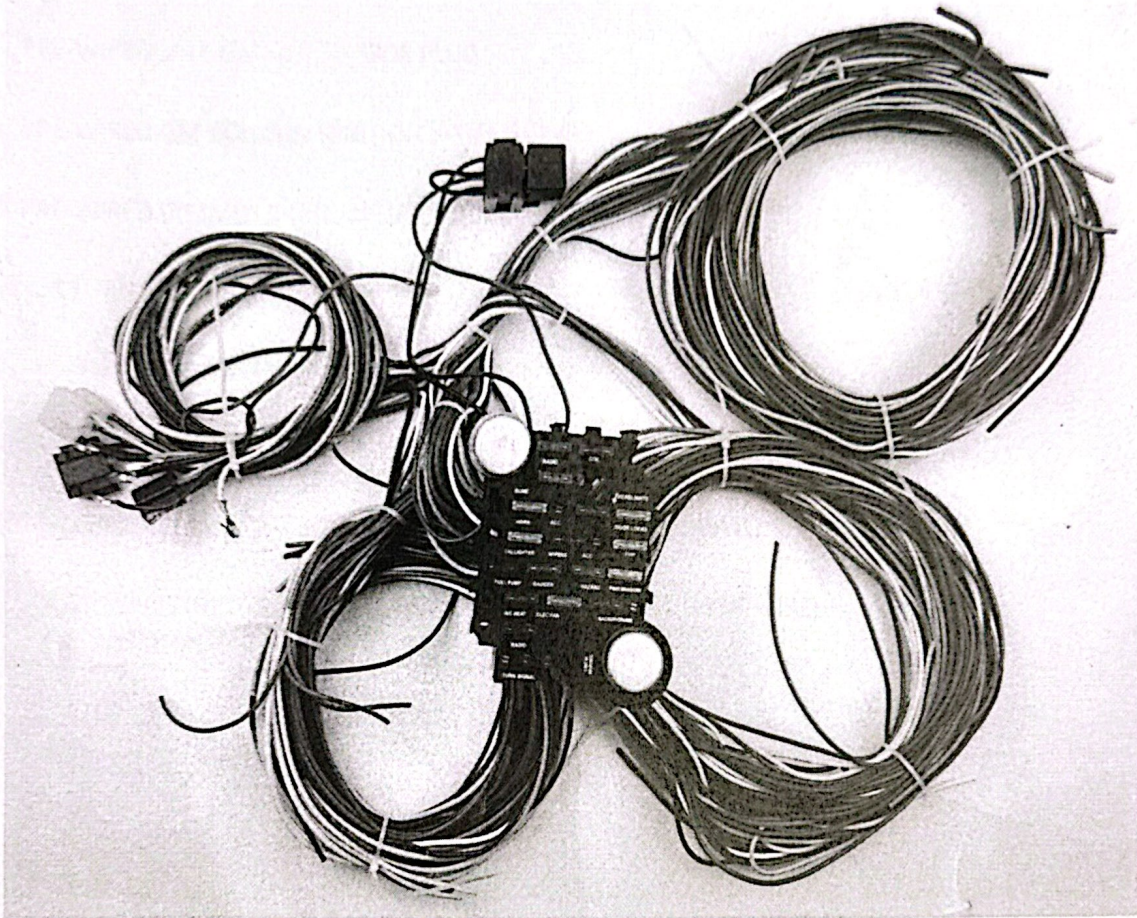

WIRING HARNESS DIRECTIONS

21 CIRCUIT WIRING HARNESS

THIS KIT CONTAINS THE FOLLOWING:

- 1 PRE-WIRED FUSE PANEL WITH 17 FUSES AND 1 BREAKER
- 2 SIGNAL FLASHERS AND 1 PRE-WIRED RELAY CONNECTOR WITH HORN RELAY
- 2 PRE-WIRED HEADLIGHT PLUGS
- 1 PRE-WIRED LATE GM ALTERNATOR PLUG
- 2 PRE-WIRED GM COLUMN IGNITION SWITCH PLUGS
- 1 PRE-WIRED DIMMER SWITCH PLUG
- 2 GM TURN SIGNAL CONNECTORS FOR THE PRE-TERMINATED WIRES (3 7/8" AND 4 1/4")
- 1 FUSIBLE LINK (3" BLACK WIRE WITH RING TERMINAL)
- 1 LARGE GROMMET
- 30 PLUS MISCELLANEOUS INSULATED TERMINALS AND SOME SMALL CABLE TIES
- 2 LOOSE WIRES (NEUTRAL SAFETY SWITCH WIRE AND PANEL LIGHT WIRE)

STEP #1 READ THESE INSTRUCTIONS

Before starting this installation. These instructions were developed after installing this system in over a dozen different vehicles.

To aid you we have used **BOLD PRINT** to note **IMPORTANT** items and provided general diagrams for **FORD, GM and MOPAR**. There is also a **DO** and **DON'T** section that you may find useful. Please remember that these are **GENERAL INSTRUCTIONS** for your **UNIQUE** and **SPECIFIC** vehicle and you may need to **MODIFY** them for your application. Also, whenever using **AFTER-MARKET** or **SPECIALTY** equipment, always use the diagrams **PROVIDED WITH** that equipment.

This **WORKBOOK** is designed for both our labeled and color-coded harnesses. Whenever a specific wire is referred to, it will be displayed with its **LABEL** then it's **COLOR**. You are to use the destination that applies to the kit you purchased. If a diagram shows **ONLY** a color **OR** a label, then that wire is **NOT PROVIDED** by this kit. An example of this would-be **GROUND WIRES** which we **DO NOT** provide. We do recommend to use black for ground wires on our color-coded harness and white on our labeled black harness to eliminate possible confusion.

Remember this is a **WORKBOOK!!!** So, make use of the blank space we provide for your notes. Write things down so you don't forget.

STEP #2 COMPLETE THE WORK SHEET

At the back of this workbook. This should be done while looking at the vehicle, so that you can identify what accessories you will be using and what switches will be necessary. Here is where **A LITTLE PLANNING WILL SAVE A LOT OF TIME**.

The **WORK SHEET** has been divided into the same 4 basic sections that make-up your harness. They are the **FRONT SECTION, DASH SECTION, STEERING COLUMN SECTION** and **TAIL SECTION**.

For each section compare the list of wires to your application and note if it will be **USED MOVED OR REMOVED**. Before marking wires to be removed consider accessories you may want to add later or those not provided for by this kit. The design of your vehicle may require some of the wires to be moved from one section to another. (An example of this would be, if the horn was mounted on the rear of the car, you would want to move the **HORN = GREEN** wire to the tail section.)

When marking a wire to be moved **DON'T FORGET** to **WRITE IT** into the new section in the extra spaces provided. The extra spaces should also be used for any extra wires you may need to add, such as ground wires.

STEP #3 PREPARE THE HARNESS FOR INSTALLATION

For this you will need a LARGE CLEAR WORK AREA to spread out the harness. (The floor next to the project car works well.) Your harness, as purchased, will have each of the 4 SECTIONS coiled and tied with cable ties. When working with the harness, it is VERY IMPORTANT NOT TO REMOVE THE 3 CABLE TIES CLOSEST TO THE FUSE PANEL.

Start with the largest coil of wires. That will be the FRONT SECTION, so remove the cable ties and uncoil the wires toward the front of the vehicle. The next largest coil of wires will be the TAIL SECTION. Cut off the cable ties and uncoil those wires toward the rear of the vehicle. The remaining coils of wires are the DASH SECTION and the STEERING COLUMN SECTION. The STEERING COLUMN SECTION is the one with the pre-attached plugs and will not need to be changed in most applications. Remove the cable ties from the DASH SECTION and uncoil those wires to the side of the FUSE PANEL.

Now using the WORK SHEET that you completed in STEP #2, start by removing any unused wires. Work one section at a time and remove those wires ONE WIRE AT A TIME by pulling them through the remaining harness cable ties. (REMEMBER DO NOT REMOVE THE 3 TIES NEAREST THE FUSE PANEL.) Unused wires that come directly from the FUSE PANEL are HOT LEADS and should be cut as CLOSE to the back of the panel as possible. Use CAUTION and only cut wires that you are sure you will NEVER NEED!

After removing all unused wires from all sections, move on to those wires that you noted you would have to move from one section to another. Working one wire at a time move those wires to their new sections by pulling them out of their original section and passing them through the harness ties into their new sections.

Now, a section at a time, add any wires you noted you would need that are NOT PROVIDED in your kit. (Note you can use the wire you removed, but KEEP NOTES so as not to get CONFUSED.)

The last part of this step is to compare the WORK SHEET to the harness as you have it now prepared. If everything is accounted for, use cable ties and recoil the sections one at a time. If the ties nearest the panel are loose either tighten them or replace them as necessary.

STEP #4 MOUNTING THE FUSE PANEL

The FUSE PANEL of our standard harness is designed to be mounted under the dash on the driver's side of the vehicle.

The FUSE PANEL should be mounted securely to a FLAT SURFACE. Care should be taken to keep it and the wires away from MOVING OBJECTS such as gas and brake controls and the panel SHOULD BE ACCESSIBLE in case you ever blow a fuse. When selection the panel location make sure that the STEERING COLUMN SECTION WILL REACH YOUR COLUMN.

After selecting the location for the FUSE PANEL, determine the best place to mount the horn relay that's pre-wired to the panel. We have provided ample length so that you may mount the relay anywhere near the panel.

Now that the FUSE PANEL and HORN RELAY are mounted, note where the FRONT SECTION wires exit the panel. Find a spot on the fire wall where these wires can enter the ENGINE COMPARTMENT without interfering with other components, such as brake boosters, wipers, the engines, steering gear, etc. At that spot drill, a 1 1/4" HOLE and install the grommet provided in your kit.

As the last part of this step, remove the cable ties you put on the FRONT SECTION wires and pass them through the grommet into engine compartment ONE WIRE AT A TIME.

STEP #5 ROUTING AND ATTACHING THE WIRES.

In this step, you will be completing the job by terminating all those loose ends. As before this will be done section by section. We suggest you start with the TAIL SECTION and end with the DASH SECTION. Each section has its own set of instructions and we suggest you review the DO and DON'T page and your WORK SHEET before starting each section. As you complete each section use cable ties to group the wires together and at points where wires branch off from the harness.

The TAIL SECTION harness is designed to be routed to the back of the vehicle inside along the floor. The wires can be taped to the floor or run under the driver's side door sills. They need to be routed where they WON'T BE WALKED ON and where the seats won't interfere. At the rear of the vehicle you will attach the wires to your lights, gas tank sender, and fuel pump as indicated on the TAIL SECTION DIAGRAM. Please note also that the DOME LIGHT power wire is included in the TAIL SECTION.

The FRONT SECTION wires include the front lighting, engine and accessories normally mounted on the front of the vehicle. For this section start by separating the ENGINE wires from the rest. When installing the front lighting and accessory wires follow the FRONT LIGHTING DIAGRAM. When installing the ENGINE, WIRING use the diagram from the FORD, GM or MOPAR section that comes closest to your vehicle. Remember when connecting the 10 GA. SOLENOID PWR = RED wire to use the FUSIBLE LINK provided in your kit. Failure to install the FUSIBLE LINK VOIDS ALL WARRANTY on this harness system. If you are using an AMP METER, please follow the AMP METER section on the DASH DIAGRAM.

The STEERING COLUMN SECTION has the wires for your turn signals, ignition switch and dimmer switch. The plugs on these wires are for a GM STEERING COLUMN that has a column mounted ignition switch. If you are using that type of column, plug the black and clear plugs into the ignition switch. The dimmer switch plug will fit a floor mounted dimmer or the GM column mounted dimmer. The turn signal wires are pre-terminated and you will be using the diagram in the GM SECTION to determine the correct plug and order that the wires should be installed. Note that the plugs are letter coded to help.

If you are using a LATE MODEL GM VAN type column the turn signals will match the plugs in your kit but you must use IGNITION SWITCH DIAGRAM in the DASH DIAGRAM.

If you are using a FORD or MOPAR COLUMN use the diagrams in the FORD and MOPAR SECTIONS. But REMEMBER because they change colors often, these interchanges may NOT match your column. If the colors don't match or you're using something not listed, you may have to sort the turn signal wires out with an ohm meter. Most original ignition switches are marked on the back of the switch.

The DASH SECTION contains the wires for the gauges, the headlight switch, radio power leads, heater, wiper and cooling fan switches. The order you install these wires depends greatly on your dash configuration. Here it is best to start working from the driver's side of the dash toward the passenger's side. Use the cable ties provided in your kit to tie up the harness as you go.

By now you should be out of wires. All that remains is a simple start up procedure. Start by turning OFF ALL ACCESSORIES. Place the ignition switch in the OFF position and close the doors to make sure the dome light is off. Now connect the POS. BATTERY CABLE. BEFORE connecting the NEG. CABLE, you should check for a current draw. This can be done easily with a test light connected between the neg. Battery post and the neg. Battery cable. No light- no draw. If you have no draw or just a dim light, it is safe to connect the neg. Battery cable and start checking the system.

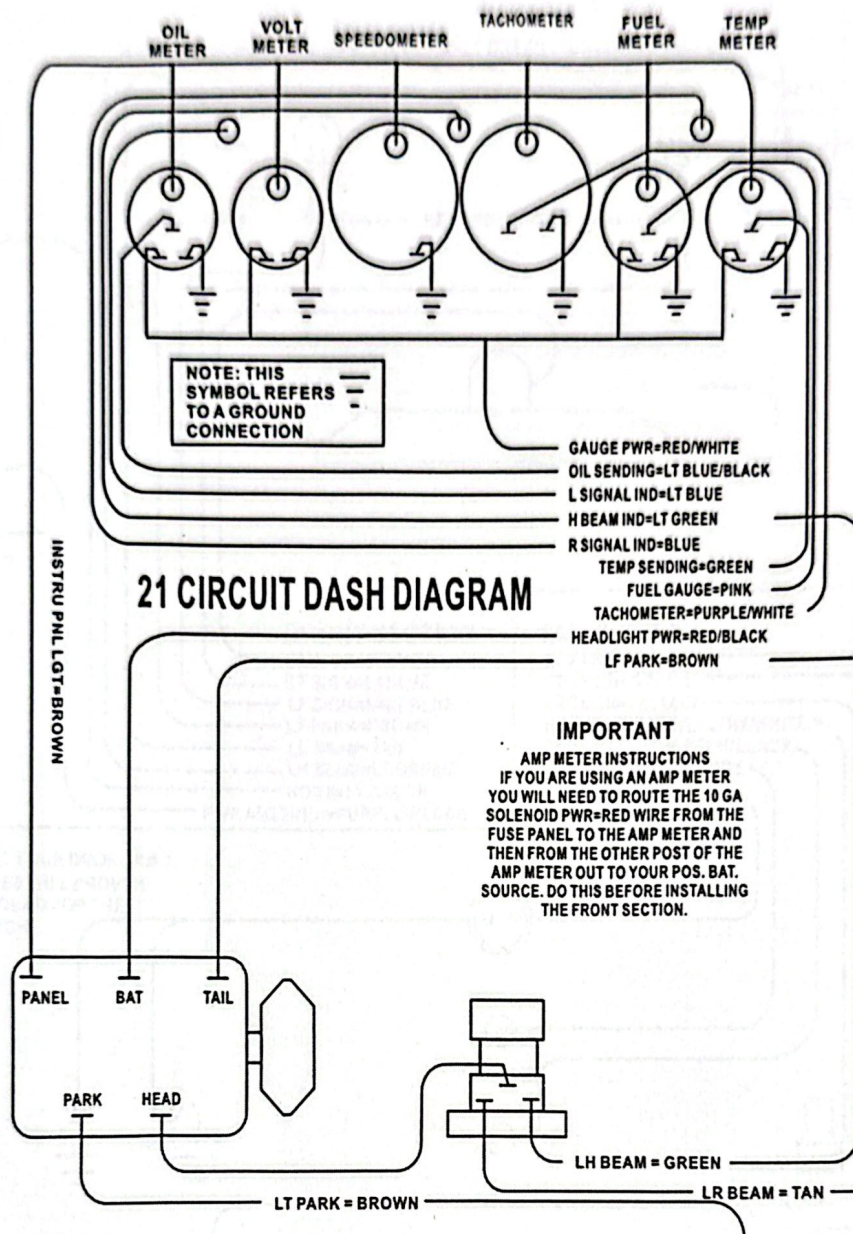

21 CIRCUIT FRONT SECTION DIAGRAM

21 CIRCUIT TAIL SECTION DIAGRAM

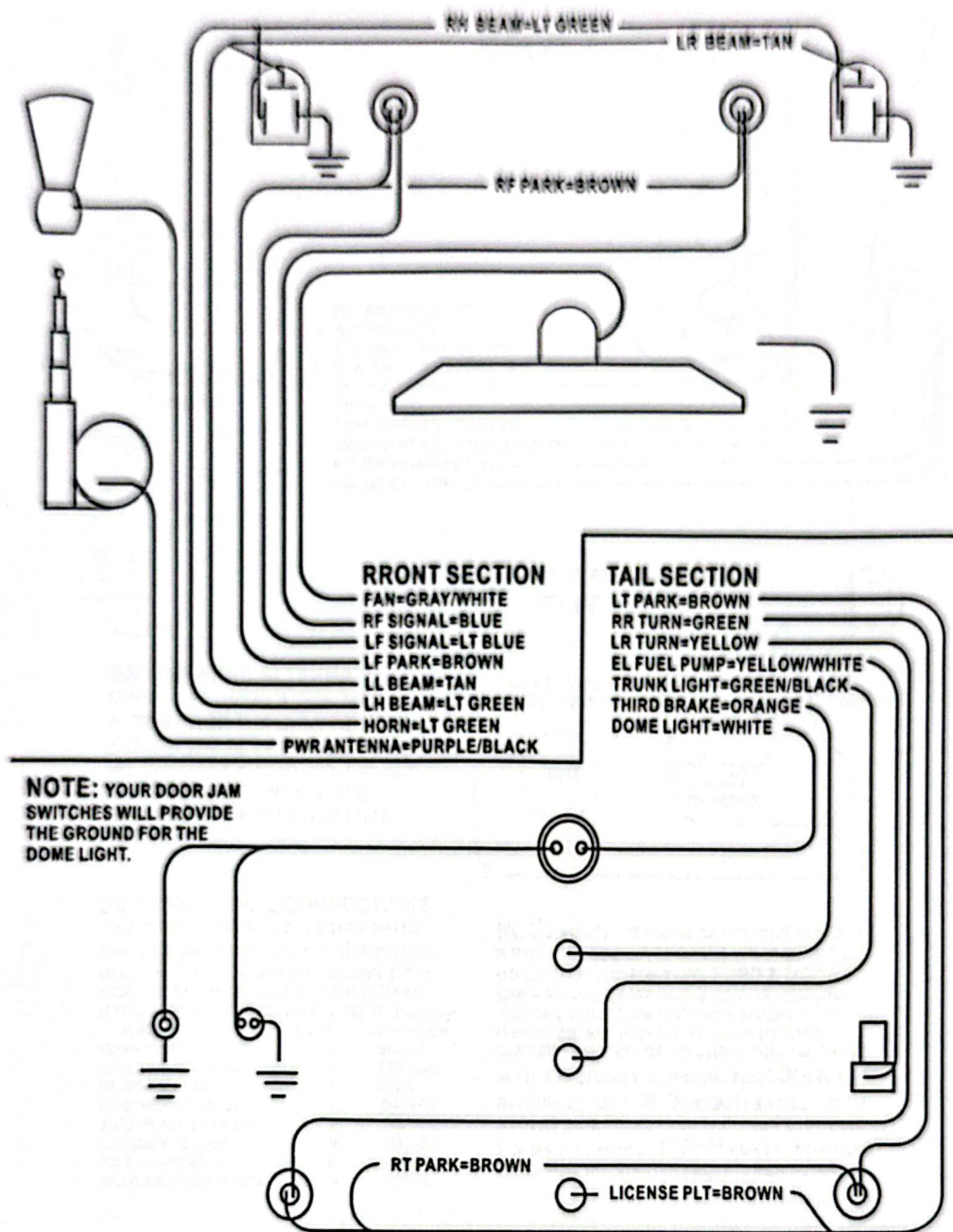

21 CIRCUIT TAIL SECTION DIAGRAM

CHARGING SYSTEMS

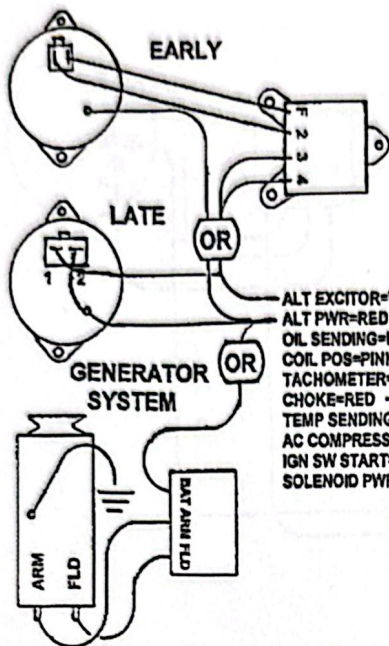

GM DIAGRAMS

- ALT EXCITOR=WHITE
- ALT PWR=RED
- OIL SENDING=LT BLUE/BLACK
- COIL POS=PINK
- TACHOMETER=PURPLE/WHITE
- CHOKE=RED
- TEMP SENDING=LT GREEN
- AC COMPRESSOR=BLACK/WHITE
- IGN SW START=PURPLE
- SOLENOID PWR=RED

GM ONE-WIRE ALTERNATOR
 IF YOU ARE USING A ONE-WIRE ALTERNATOR THE ONLY WIRE YOU NEED IS THE ALT PWR=RED WIRE. WE SUGGEST YOU STORE THE ALT EXCITOR=WHITE WIRE IN THE HARNESS IN CASE YOU NEED IT LATER.

GM TURN SIGNAL CONNECTIONS
 YOUR TURN SIGNAL WIRES ARE TERMINATED FOR THE CONNECTORS THAT FIT GM COLUMNS. MEASURE THE PLUG ON YOUR COLUMN. IF IT IS 3/8" USE THE FLAT CONNECTOR IN YOUR KIT. IF IT IS 1/4" USE THE CONNECTOR WITH THE FLAP.

WIRE	CODE	GM COLOR
HORN SW=LT GREEN	G	BLACK
LF SIGNAL=LT BLUE	H	LT BLUE
RF SIGNAL=BLUE	J	BLUE
HAZZARD=DK BROWN	K	BROWN
TURN FLASHER=PURPLE	L	PURPLE
LR TURN=YELLOW	M	YELLOW
RR TURN=GREEN	N	GREEN
BRAKE SWITCH=WHITE	P	WHITE

GM STANDARD IGNITION (POINTS TYPE)

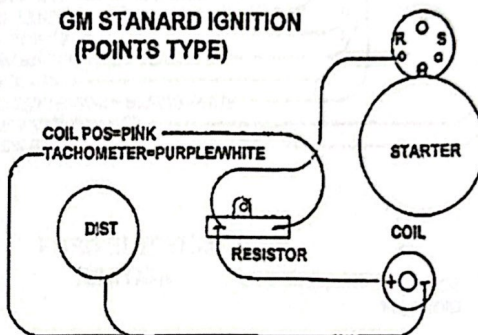

NOTE: POINTS TYPE IGNITION SYSTEMS REQUIRE A BALLAST RESISTOR TO LOWER VOLTAGE TO THE COIL AND EXTEND POINT LIFE. FORD & MOPAR USE A RESISTOR WIRE ORIGINALLY FOR THIS, BUT YOU CAN SUBSTITUTE WITH THE CERAMIC TYPE. IT IS IMPORTANT TO ALSO INSTALL A BY-PASS WIRE SO THAT THE COIL WILL HAVE FULL VOLTAGE WHEN THE ENGINE IS CRANKING. FOR GM USE THE DIAGRAM ABOVE. FORD WIRES THE SAME BUT THE BY-PASS WIRE COMES FROM THE STARTER SOLENOID TERMINAL MARKED I. MOPAR RUNS THE BY-PASS WIRE FROM THE STARTER RELAY TERMINAL IGN.

CHARGING SYSTEM

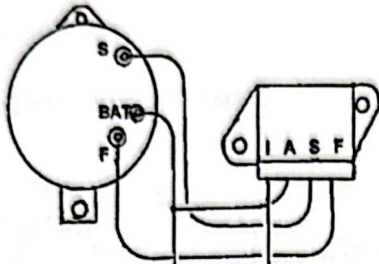

FORD DIAGRAMS

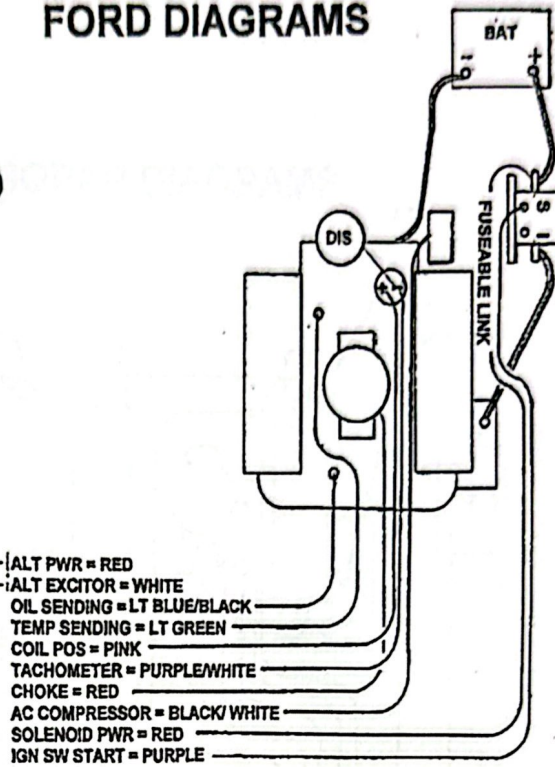

IGNITION SWITCH CONVERSION

IGN-SW PWR = RED	TO	YELLOW
IGN SW IGN = PINK	TO	RED/GREEN
IGN SW ACC = ORANGE	TO	BLACK
IGN SW START = PURPLE	TO	WHITE/BLUE

STEERING COLUMN CONVERSION

LF SIGNAL = LT BLUE	TO	GREEN/WHITE
RF SIGNAL = BLUE	TO	WHITE/BLUE
LR TURN = YELLOW	TO	GREEN/ORANGE
RR TURN = GREEN	TO	ORANGE/BLUE
HORN SW = LT GREEN	TO	YELLOW
BRAKE SW = WHITE	TO	GREEN
TURN FLASHER = PURPLE	TO	BLUE
HAZZARD = DK BROWN	TO	WHITE/RED

FORD ELECTRONIC IGNITION

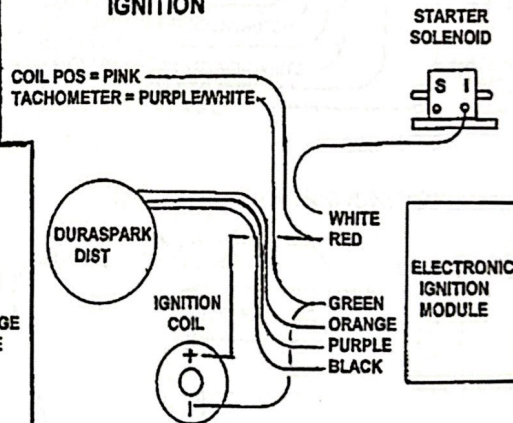

CHARGING SYSTEMS

MOPAR DIAGRAMS

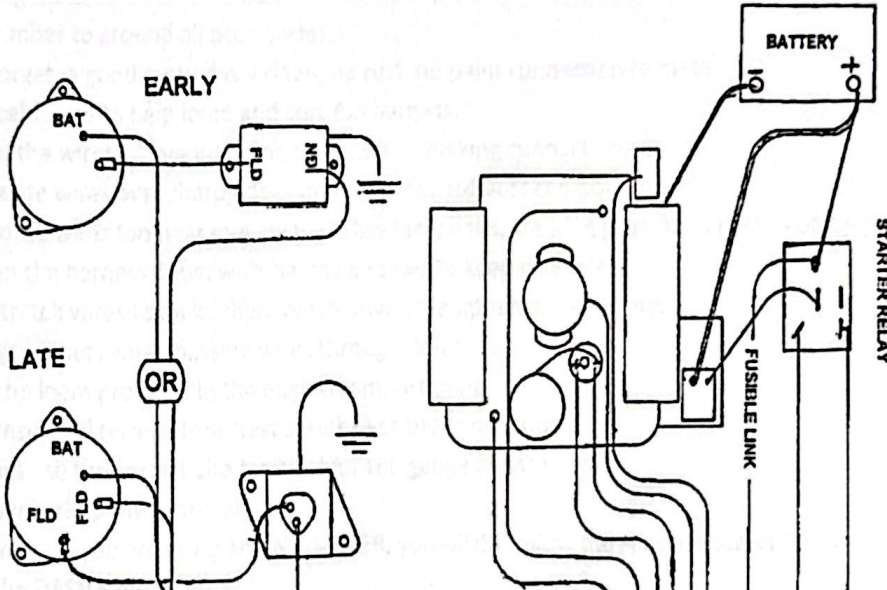

TURN SIGNAL CONVERSION

1970-1974

- | | |
|---------------------|-------------|
| LF SIGNAL=LT BLUE | TO GREEN |
| RF SIGNAL=BLUE | TO TAN |
| LR TURN=YELLOW | TO DK GREEN |
| RR TURN=GREEN | TO BROWN |
| HORN SW=LT GREEN | TO BLACK |
| BRAKE SW=WHITE | TO WHITE |
| TURN FLASHER=PURPLE | TO RED |
| HAZZARD=DK BROWN | |

EARLY 80'S

- | | |
|---------------------|-----------------|
| LF SIGNAL=LT BLUE | TO LT GREEN |
| RF SIGNAL=BLUE | TO TAN |
| LR TURN=YELLOW | TO DK GREEN/RED |
| RR TURN=GREEN | TO BROWN/RED |
| HORN SW=LT GREEN | TO BLACK/RED |
| BRAKE SW=WHITE | TO WHITE |
| TURN FLASHER=PURPLE | TO RED |
| HAZZARD=DK BROWN | TO PINK |

IGNITION SWITCH CONVERSION

- | | |
|---------------------|-----------|
| IGN SW PWR=RED | TO RED |
| IGN SW IGN=PINK | TO BROWN |
| IGN SW ACC=ORANGE | TO BLUE |
| IGN SW ACC=BROWN | TO BLACK |
| IGN SW START=PURPLE | TO YELLOW |

MOPAR ELECTRONIC IGNITION

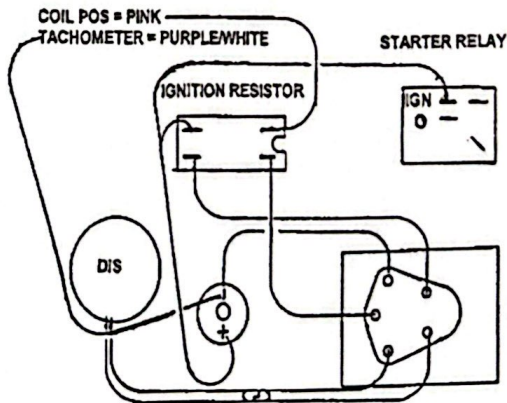

21 CIRCUIT WIRING TIPS AND TRICKS!

DON'T let the size of this job scare you. We make this installation an easy job.

DON'T start this installation before disconnection both battery cables.

DO install main ground cables from the engine to the frame and from the engine to the body.

Main ground cables should be the same size as the battery cables.

DO remember to ground all accessories.

DON'T forget, a good ground is a clean, no rust, no paint connection to metal.

DO use cable ties to help loom and sort the harness.

DO route the wires before installing terminals or making connections.

DON'T route wires over sharp edges or next to the exhaust components.

DON'T route wires too near moving parts like fans, belts, steering gear, hood latches or hinges.

DO fasten the harness down with clamps and ties to keep it secure.

DON'T stretch wires to make them reach. Always lengthen as necessary.

DO use grommets when passing wires through holes.

DO use the loom provided in the engine compartment.

DO use insulated terminals or heat shrink over the connections.

DO always use the correct size terminal for the gauge of wire.

DON'T over crimp the terminals.

DON'T forget if you are using an AMP METER, you MUST follow the special instructions on the DASH DIAGRAM.

DO use the diagrams provided with after-market of specialty accessories.

DON'T skip around start a section and finish it.

DON'T forget to do the WORK SHEET. It will save you a lot of time.

DON'T forget these are only GENERAL instructions and you may need to modify them for your vehicle.

DON'T discard these instructions when you are finished. This workbook and your notes will be useful later if you are adding on or making repairs.

DASH IGNITION SWITCH

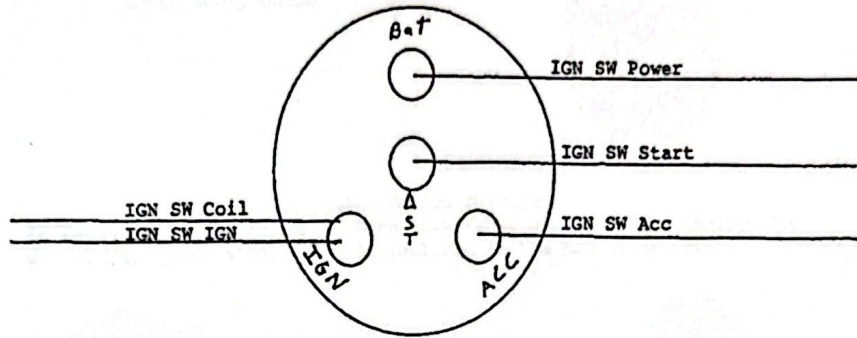

G M HEADLIGHT DIAGRAM

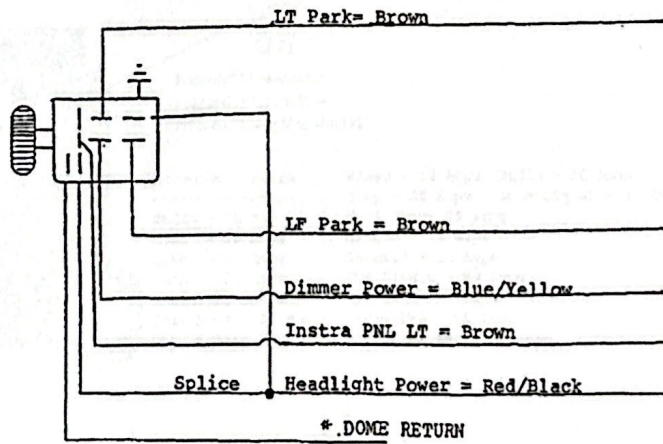

Neutral Safety Switch

You will cut the ignition switch start wire and attach both ends to each port on the switch. This ends by connecting to the "S" terminal on the starter.

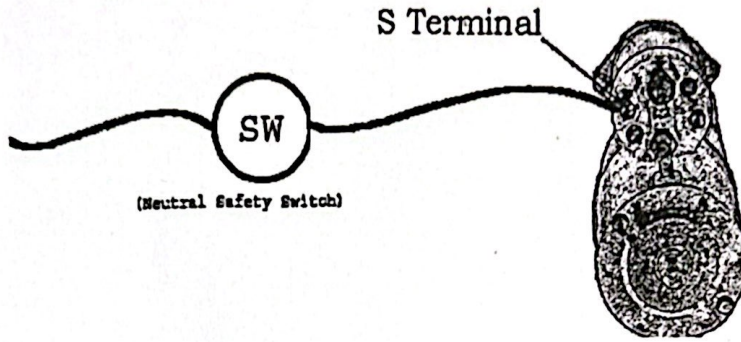

Alternator Bypass Circuit

If You are using an 80 amp or more alternator here is the schematic for use of the bypass wire, which is included in the bag of material.

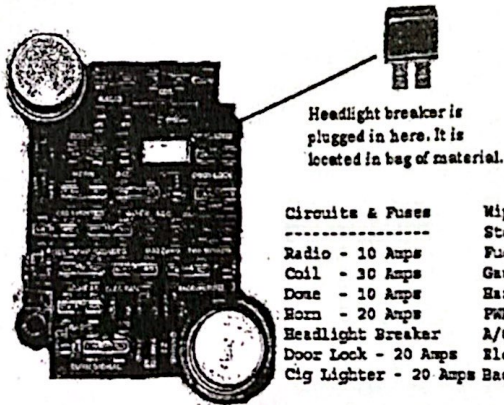
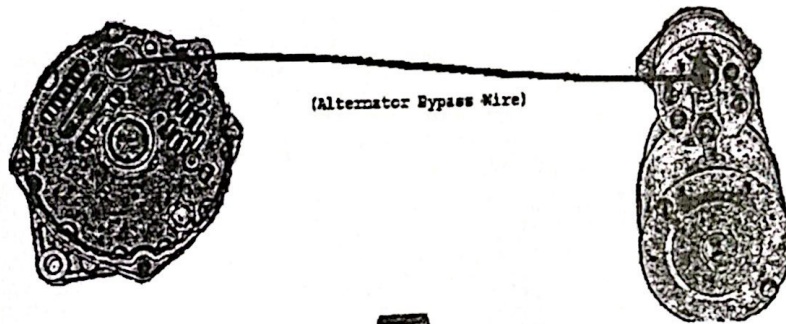

- | | | |
|-----------------------|-------------------------|-----------------------|
| Circuits & Fuses | Wiper - 15 Amps | Radio - 10 Amps |
| ----- | Stop - 20 Amps | Turn Signal - 15 Amps |
| Radio - 10 Amps | Fuel Pump - 15 Amps | |
| Coil - 30 Amps | Gauges - 10 Amps | |
| Door - 10 Amps | Hazzard - 15 Amps | |
| Horn - 20 Amps | PWR Window - 20 Amps | |
| Headlight Breaker | A/C Heat - 30 Amps | |
| Door Lock - 20 Amps | Elect Fan - 20 Amps | |
| Cig Lighter - 20 Amps | Backup/Cruise - 10 Amps | |